

SCOTSMAN

MODULAR AIR, WATER, REMOTE COOLED FLAKE ICE MACHINE



FME1504

VOLUME PRODUCTION • 24 HOUR

Based on Air/Water Temperatures	Air-Cooled		Water-Cooled		Remote	
	70°/50° lbs./kg.	90°/70° lbs./kg.	70°/50° lbs./kg.	90°/70° lbs./kg.	70°/50° lbs./kg.	90°/70° lbs./kg.
FME1504-32	1430/649	1110/503	1460/662	1220/553	1280/581	1100/499

SCOTSMAN'S NEW FLAKED ICE MACHINES with AutoSentry™

- AutoSentry™ Monitoring System constantly checks workload on gearbox shutting down system before a problem develops preventing costly repairs.
- Electrical conductivity water sensor eliminates low or no water failures and cannot be affected by adverse water conditions.
- Plastic drain pan with larger outlet provides greater ability to quickly channel water away preventing particulate build-up and rust.
- Rust and restriction free drain system features one-piece plastic drain tubes with larger ID for obstruction-free water flow.
- Durable, high grade stainless steel construction with massive, self-aligning spherical roller bearings; patented double-flight auger that evenly distributes the load; and heavy duty direct drive gearbox for high reliability and long life.

WARRANTY See your dealer for complete warranty details.

- 3 years parts on all components.
- 3 years labor on all components.
- 5 years parts on compressor.

BIN OPTIONS:



BIN: BH550



BIN: BH801



FLAKED ICE

Inexpensive to produce, used in produce and fish displays.

SCOTSMAN MODULAR BINS

 Certified & rated in accordance with ARI standard B20-95

Model Number	Dimensions W" x D" x H"	ARI Bin Capacity	Application Capacity	Finish	Ship Weight lbs./kg.
HTB250	30 x 31.5 x 22.5	190	250	HTB	80/36
HTB350	30 x 31.5 x 29.5	250	350	HTB	90/41
HTB555	30 x 34.5 x 44.5	420	535	HTB	110/50
BH550S-C	30 x 31.5 x 44	410	520	SS	140/64
BH801S-A*	42 x 31.5 x 44	580	740	SS	165/75
BH900S-C*	48.2 x 33.75 x 44	740	940	SS	185/84
BH1100	48 x 34 x 50	860	1100	BB OR SS	280/127
BH1300**	60 x 34 x 50	1100	1400	BB OR SS	310/141
BH1600**	60 x 34 x 60	1250	1600	BB OR SS	410/186

Add 6" to Height for Legs

(HTB) Grey Polyethylene Exterior and Interior
(SS) Stainless Steel with Polyethylene Liner.

*See Price Schedule for Bintops
**Accepts 1 or 2 Units Side by Side

CERTIFIED

9001:2000

This product qualifies for the following listings:



Scotsman®

Ice Machine Specifications

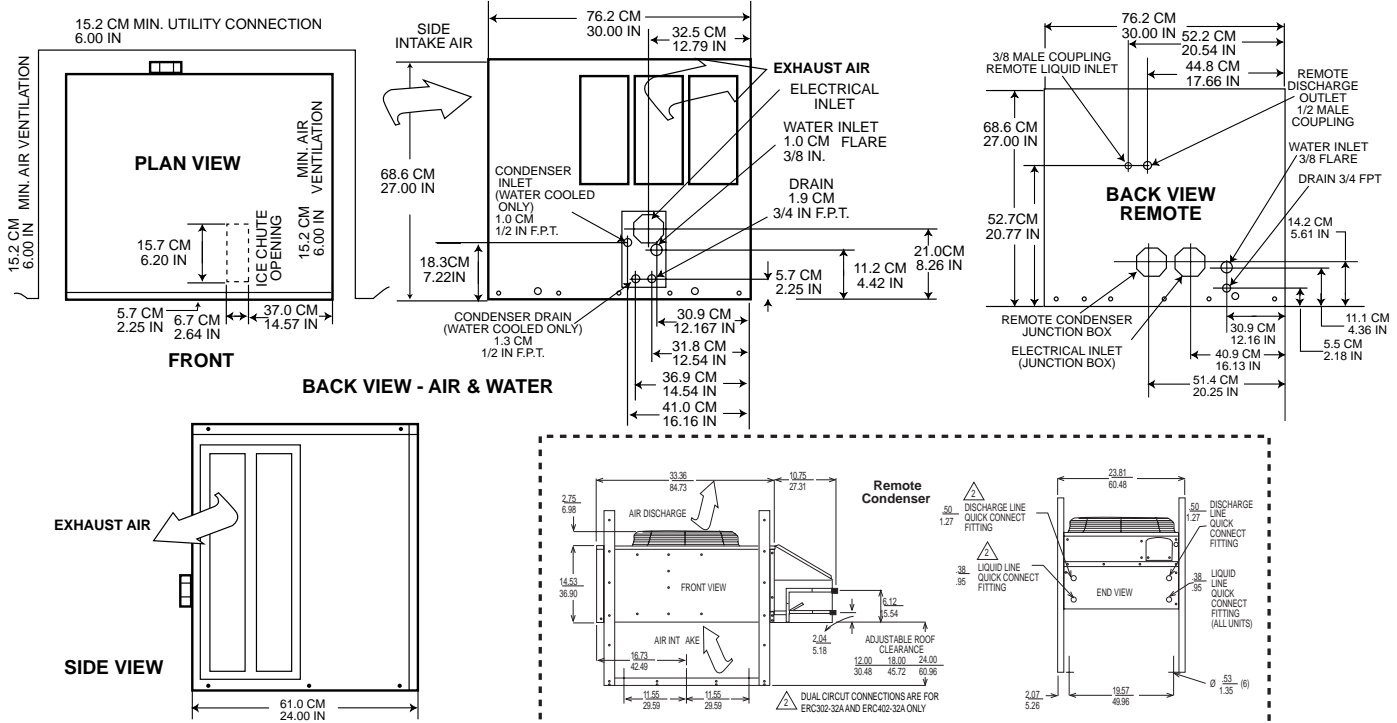

ERC201 or ERC402

INSTALLATION NOTE: Allow 6" minimum space at left side and back for ventilation and utility connections.

All models: Dimensions: W x D x H Unit: 30" x 24" x 27" Shipping Carton: 33 1/2" x 27 1/2" x 32"										
Model Number	Condenser Unit	Basic Electrical Volts/Hz/Phase	Max. Fuse Size or HACR Circuit Breaker	Comp. HP	Circuit Wires	Min. Circuit Ampacity	Shipping Weight lbs./kg.	Power Consumption KWH/100 lbs. 90°F/70°F	Water Usage Gallons/100 lbs. Potable 90°F/70°F Condenser 90°F/70°F	
FME1504AS-32B	AIR	208-230/60/1	20	1 3/4	2	15.0	285/129	3.4	12	-
FME1504WS-32B	WATER	208-230/60/1	20	1 3/4	2	14.3	285/129	2.8	12	92.3
FME1504RS-32B	REMOTE	208-230/60/1	25	1 3/4	2	17.3	285/129	3.3	12	-

All units with Stainless Steel finish.
Refrigerant: R-404A.

REMOTE CONDENSER—Comes with adjustable legs
Dimensions: W x D x H: 24.00" x 44.25" x 29.25" for ERC201
24.00" x 54.25" x 29.25" for ERC402

Model Number	For Use With	Cond. Unit	Finish Basic	Electrical Volts/Hz/Phase	No. of Wires	Min. Circuit Ampacity	Max Fuse Size or HACR Circuit Braker
ERC201-32A	(1) FME1504	Air	Galvanized	208-230/60/1	2	2.6	15
ERC402-32A*	(2) FME1504	Air	Galvanized	208-230/60/1	2	2.6	15

PRE-CHARGED REFRIGERANT TUBE KITS: 25-Foot, RTE25 • 40-Foot, RTE40 • 75-Foot, RTE75
*KCMR-230—Fan Relay Kit: Required to connect two FME1504R's to one ERC402-32A, Refrigerant: R-404A.

Scotsman's ice machines are not designed for outdoor installations. Scotsman remote condensers are designed for outdoor installations.

Machine requires voltage indicated on rating name plate. Failures caused by improper voltage are not considered factory defects. Extended periods of operation at temperatures exceeding limitations constitutes misuse under the terms of Scotsman Manufacturer's Limited Warranty, resulting in a loss of warranty coverage. Specifications and design are subject to change without notice.

Consult Your Local SCOTSMAN Representative At:

IMPORTANT OPERATING REQUIREMENTS:

	Minimum	Maximum
Air Temperatures	50°F (10°C)	100°F (37.7°C)
Water Temperatures	40°F (4.4°C)	100°F (37.7°C)
Remote Cond. Temps	-20°F (-28.9°C)	120°F (48.9°C)
Water Pressures	20 PSIG	120 PSIG
Electrical Voltage	-5%	+10%

YOU'LL VALUE THE DIFFERENCE™

775 Corporate Woods Parkway • Vernon Hills, IL 60061 • 1-800-SCOTSMAN • Fax: (847) 913-9844
Visit our website at: www.scotsman-ice.com • E-mail: customer.service@scotsman-ice.com

Scotsman®